

# Assembly Instructions

## for GULEX valve actuators

Please note before commissioning!



In order to guarantee safe, problem-free functional performance, the entire System design must be taken into account when selecting an actuator-valve combination. Valve functions, material compatibility, pressure and temperature ranges, appropriate Assembly, operation and maintenance are the responsibility of the system designer and the user.

The services, technical data, dimensions and weights specified in our catalog correspond to the latest status at the time of publication. The images are non-binding.

We reserve the right to make constructive changes. Such changes, errors and misprints do not justify any claim for damages or compensation for consequential damage.

## Protection and operating light

Only actuators of type series N802 and K8

The actuators are equipped with an operating light and a thermal fuse. This does not apply to actuators of the TA 70 series. Their electrical protection must be carried out externally!

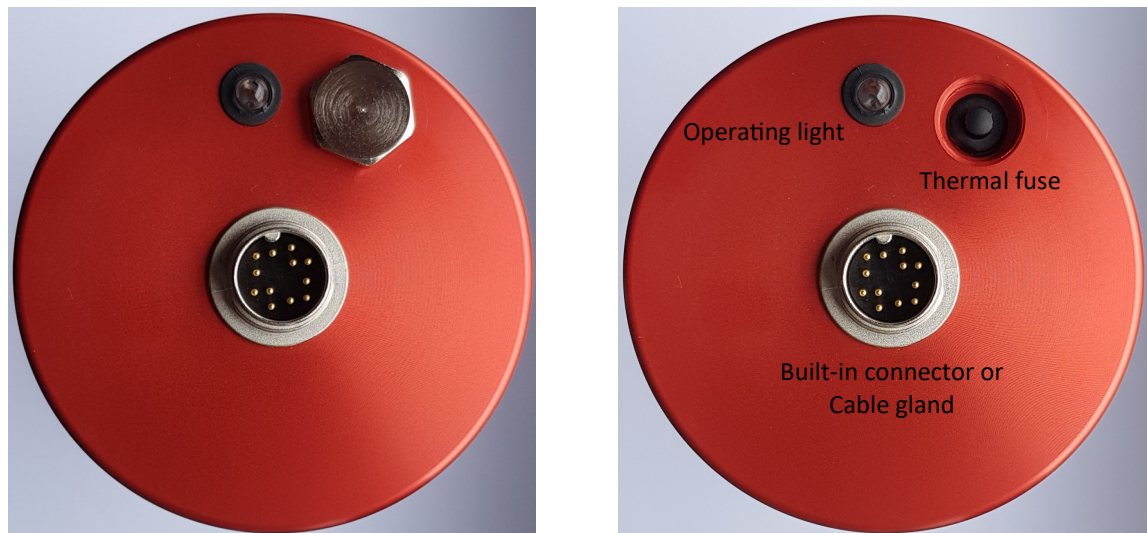

Fig. : Top view actuator with and without cover nut thermal fuse

## Function

If the actuator is overloaded, the fuse reacts and the operating light goes out.

Open the cover nut (SW 14) with an open-end wrench and press the button on the fuse that is now visible. The actuator is ready for operation again. Close the fuse again with the cover nut and its sealing element. Investigate why the fuse tripped.

## Protection class IP 67

Only actuators of type series N802 and K8

In order to achieve protection class IP 67, the actuators are equipped with the following design features

- The actuator shaft is sealed with a shaft seal
- The cover hood is equipped with O-rings
- For actuators with a plug connection, the built-in plug must be screwed to the cable socket!

## Notes on operating the actuators with ball and plug valves

The actuator and valve have been delivered to you assembled and adjusted with a test report. The technical data and information listed in the final inspection and test report, as well as additional type-specific information sheets, are an essential part of these instructions. In the event of a complaint, the unit (actuator with mounted valve) must be sent in!

### OPEN-CLOSE alternating operation, duty cycle and polarity

- The switching frequency of the motor must not be less than 0.5 s
- The duty cycle OT is 80%
- The polarity is to be carried out according to the connection plans
- Failure to do so will result in heat or electronic damage

### Vibration

- **Vibrations can damage the actuator electronics!**  
Therefore, do not expose the actuators to constant vibration, for example by attaching them to compressors, diesel engines, etc. Suitable vibration dampers are to be installed in such cases!

### Torque of the actuator and breakaway torques of ball and plug valves

- **PTFE - sealed fittings**  
In the event of a longer standstill, PTFE-sealed ball valves can develop a high RELEASE TORQUE that can be around three to five times the normal torque. We therefore recommend that you move the ball valves with the drive approx. Every 48 HOURS!
- **Kel-F - sealed fittings**  
In the high pressure range from approx. 250 - 450 bar, Kel-F sealed fittings are often used. These can be operated with the actuators if the manufacturer's lubricants in the fittings are not removed!

## Do not operate the actuator under the following conditions

- **Removal of lubricant through special cleaning of the valves**, among other things in connection with one-sided high pressure load from approx. 300 bar against atmosphere.
- **Leaching of the lubricant from the valves** due to daily operation should be limited by maintenance.
- **Kel-F and / or Nylatron sealed valves without lubricant** can seize according to the operating conditions described! The torques of the actuators are then exceeded! Without electrical protection of the actuators (from the outside), heat damage will result!

If our instructions are taken into account, a long, trouble-free operation of our devices is ensured!

If you should ever have a problem that you cannot cope with with the information given here, we ask you to call us.

## Pin assignments angled sockets, type Binder

Only actuators of type series N802 and K8 with built-in connector (view on solder side)

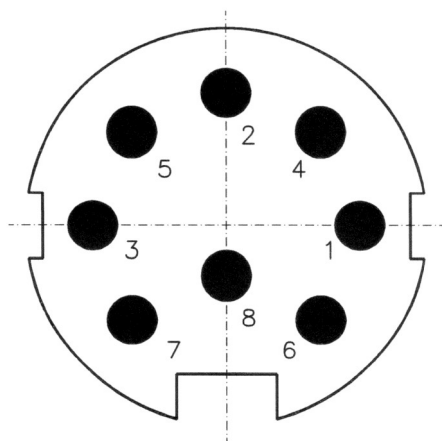

Fig. : 8 pol. Angled box

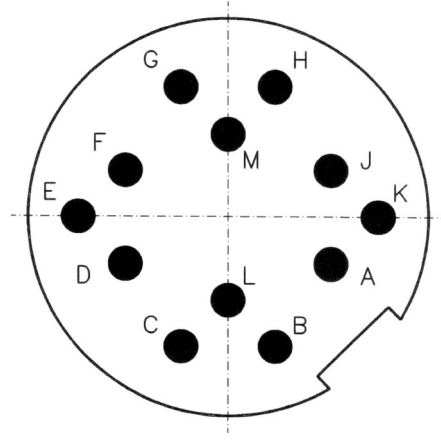

Fig. : 12 pol. Angled box

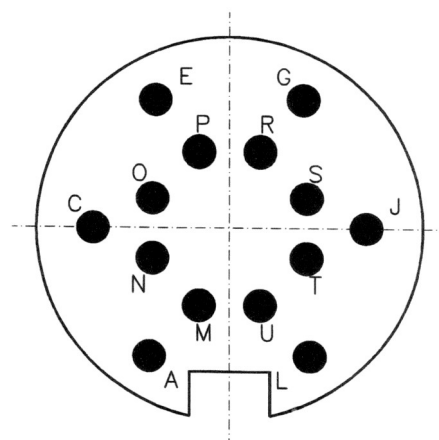
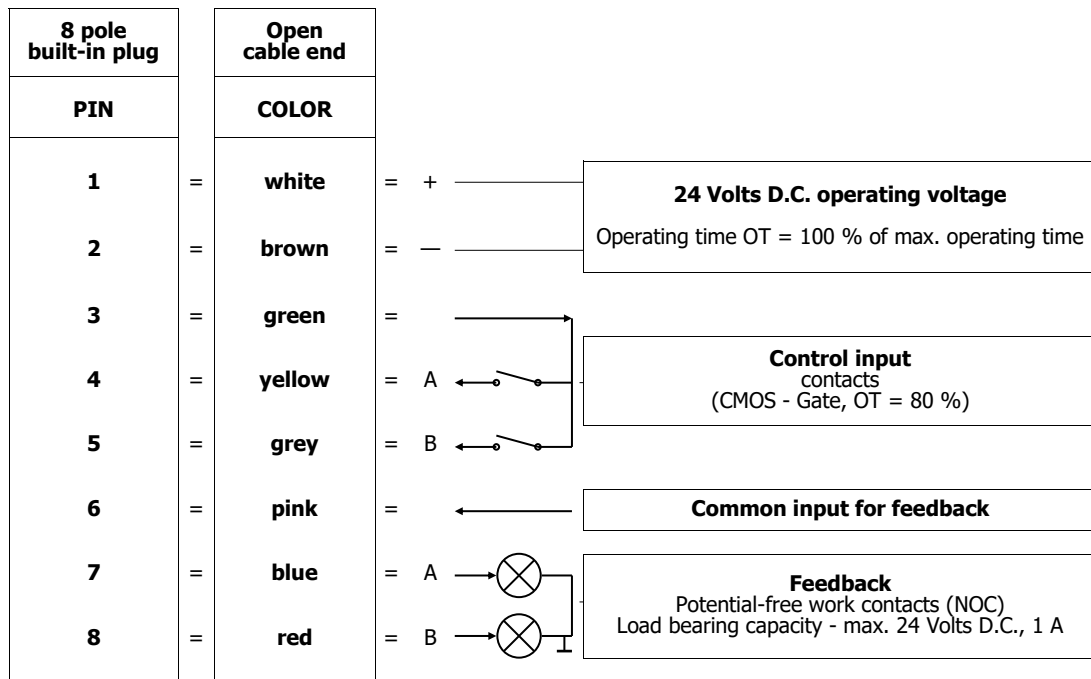

Fig. : 14 pol. Angled box

## Connection diagram K8/2W and TA70/2W



### NOTES

The power supply must be switched off during electrical installation of the actuator.

- After switching on the operating voltage, the actuator adjusts itself to its basic factory setting and rotates to position A (valve CLOSED).
- Position B (valve OPEN) can be programmed on request.
- Direction of rotation: The actuator reverses automatically.

## Connection diagram K8/3W and TA70/3W

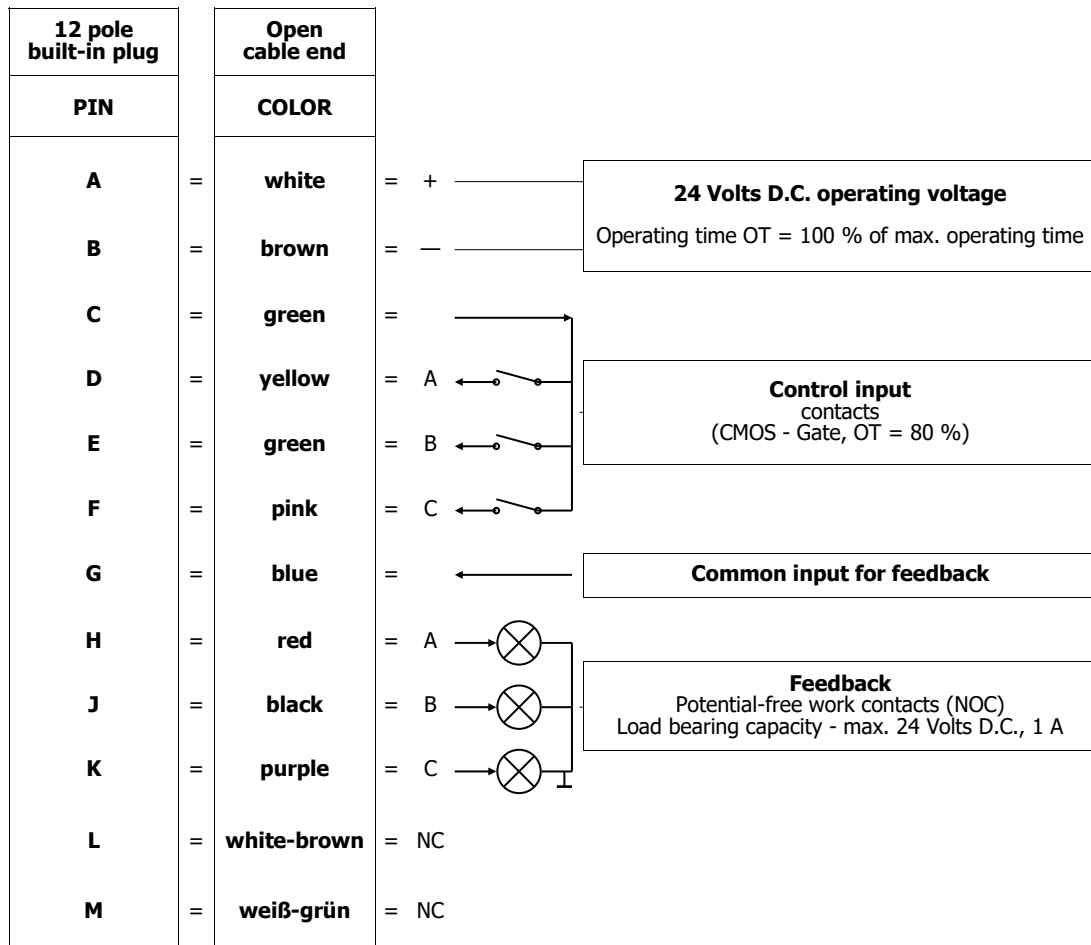

### NOTES

The power supply must be switched off during electrical installation of the actuator.

- After switching on the operating voltage, the actuator adjusts itself to its basic factory setting and turns to position B. (valve CLOSED)
- Positions A and C (valve OPEN) can be programmed on request.
- Direction of rotation: The actuator reverses automatically.

## Connection diagram K8/4W and TA70/4W

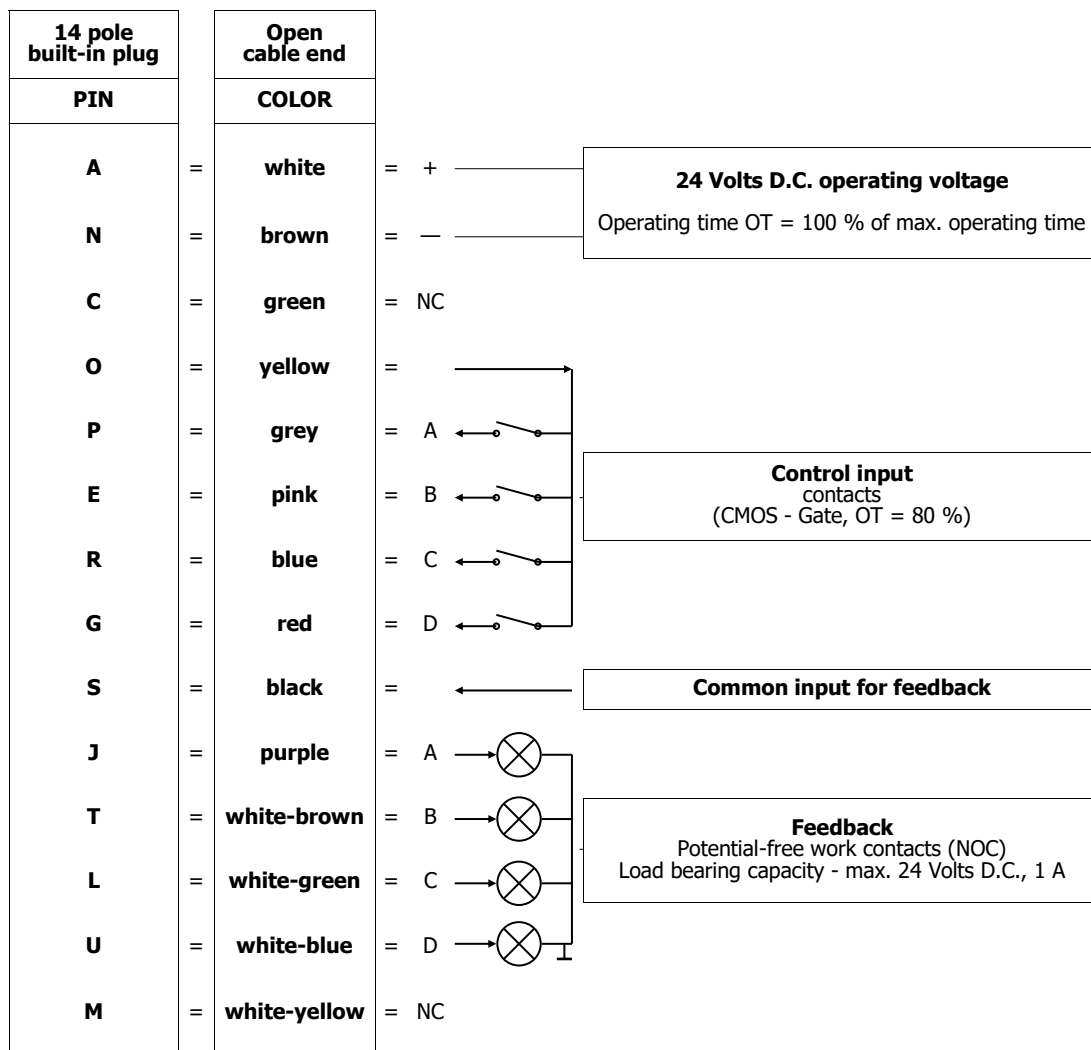

### NOTES

The power supply must be switched off during electrical installation of the actuator.

- After switching on the operating voltage, the actuator adjusts itself to its basic factory setting and turns to position D.
- Positions A, B or C can be programmed on request.
- Direction of rotation: The actuator reverses automatically.